

D.G. COUPLINGS TYPE D for TT GAUGE and OO9

Fret of 16 delayed operation
autocouplings, including
loop and dropper wires

Use with PK MAG
electromagnets

PARTS OF THE COUPLING

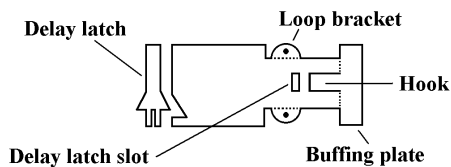

Use a craft knife or sharp scissors to cut the parts from the fret.

ASSEMBLY INSTRUCTIONS

The steps shown in Figure 1 match the paragraph numbers below.

1. Separate a coupling and delay latch from the fret and clean up with a small file.

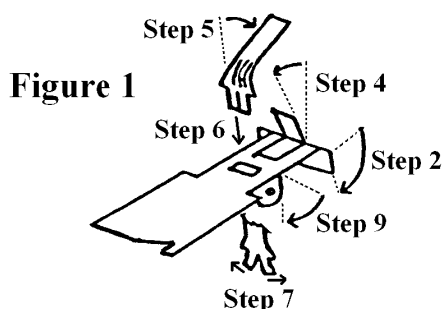

Figure 1

2. Bend the buffing plate down 90° (with the fold line on the inside of the bend) and allow the hook to rise.

3. Add a fillet of solder inside the bend for strength. The ends of the buffing plate may be bent inwards to aid operation on curved track.

4. Bend the hook back 20°.

5. Curve the delay latch about 30° as shown.

6. Put the fingers of the delay latch through the slot in the coupling, from the top, with the curve facing the hook.

7. Spread the fingers apart to retain the hook.

Figure 2a 2b



8. Adjust the curve made in 5 above so the delay latch:

- rests on top of the hook by its own weight when the coupling is held level (Figure 2a); and
- is less than vertical when lifted, so it will fall back onto the hook when released (Figure 2b).

9. Bend the loop brackets down 90°.

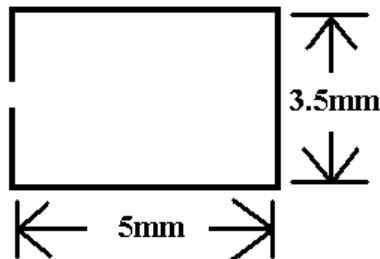

Figure 3

10. Bend a piece of phosphor bronze wire as shown in Figure 3; the dimensions are measured inside the loop. Use tapered pliers, marked at the appropriate distances to ensure each loop is the same, or use the *LBJAD* loop bending jig.

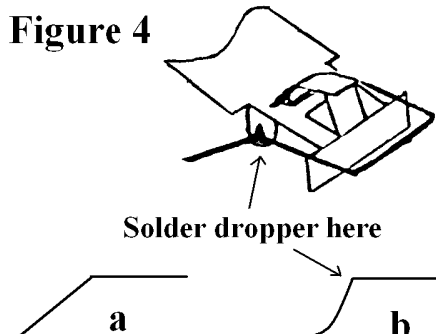

Figure 4

11. Hold the loop in a vice or clamp and solder a piece of the steel wire to the outside as shown in Figure 4. There are two options:

- straight, set back about 45°; or
- curved, which possibly works better.

12. Spring the loop into the loop bracket holes and spot solder the ends together, thus preventing the loop springing out when hauling heavy trains.

13. The complete coupling may now be primed and painted, or preferably treated with a proprietary metal blackening solution. Be sure to keep the top (fixing) surface paint free.

MOUNTING AND ADJUSTING THE COUPLING

Most kit-built vehicles have an open-frame arrangement of solebars and headstocks assembled around the wagon floor, whereas RTR stock tends to have a flat surface level with the bottom of the headstock and solebars. For RTR stock, remove as much of the old coupling mounting as is necessary to give a clear, flat area 5mm wide by 5mm deep at the very end of the vehicle. For kit-built stock, use plasticard to fill in a similarly sized area immediately behind and flush with the bottom of the headstock.

Roughen up the vehicle base and the plate's top surface to provide a key for the adhesive. Offer up the coupling to the vehicle, so that as seen from above, the buffing plate is slightly forward of the buffers. This distance should be increased if you have tightly-curved track.

Glue the coupling in place using an impact adhesive such as Evostik, having checked that the adhesive does not harm the vehicle. Epoxy resin is also suitable, but not superglue, as this may shear when subject to end-on forces. Solder may also be used for brass kits, or you may simply drill the coupling and vehicle and screw it in place.

A recommended height of the coupling above rail level is not given, as it will depend on the scale/gauge you model, but the coupling will work better the nearer to the magnet it is. However, it is important that all couplings should be at the same height. The length of the dropper should be adjusted to equal the distance between the hole in the loop bracket and the rail top.

OPERATION

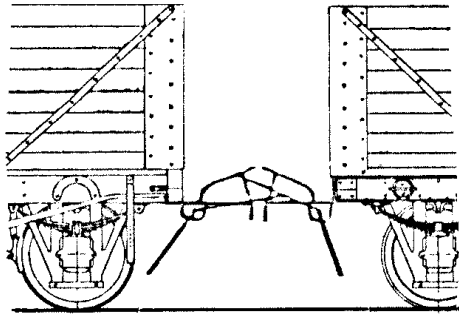

Coupling:

When the couplings meet, the loops rise up the hooks and under the delay latches, dropping down behind the hooks. One loop may end up on top of a delay latch, but the other will be coupled.

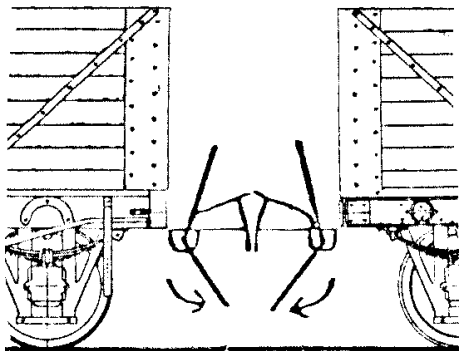

PK MAG
electromagnet

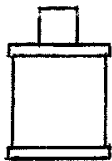

Uncoupling:

To uncouple, ease the couplings or push slowly over an energised electromagnet. The steel wire droppers are attracted and lift the loops. The delay latches fall back onto the hooks.

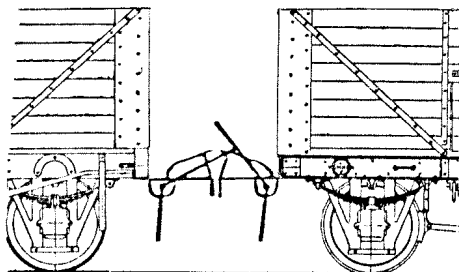

Delayed action:

De-energise or push beyond the magnet and the loops fall onto the top of the delay latches. The couplings are now in the delayed position and can be pushed without recoupling.

LOCATION OF MAGNETS

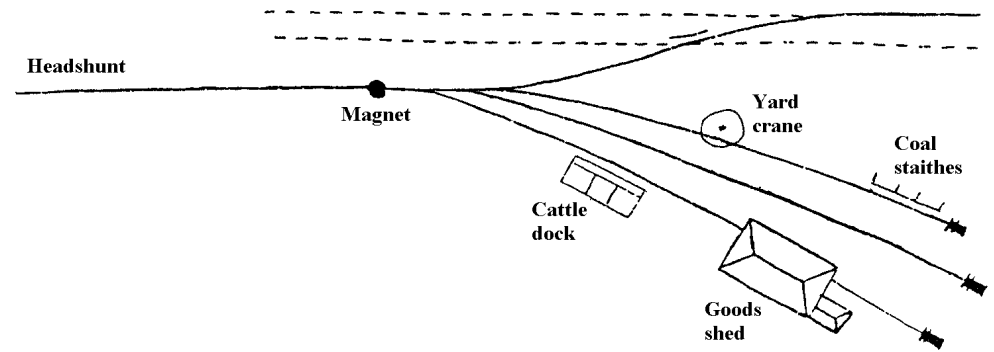

Magnets should be placed at any point where uncoupling is desired, remembering that with the delayed operation feature, wagons can be uncoupled and then pushed as far as needed without recoupling taking place. All the track depicted as a solid line in the example above may be shunted with just the one magnet shown. At pointwork, ensure that the magnet position does not leave wagons within the fouling point of the converging track.

As the dropper wires will slowly become magnetised with repeated use, reliable operation is aided by ensuring that all magnets have the same pole uppermost. Use a marked pole of a permanent magnet, and check for repulsion when the electromagnet is energised.

Once ballasted over, the electromagnet will be invisible, so don't forget to place a small trackside marker to remind you where it is.

© Wizard Models 2007