

# LNER/ BR(E/NE) UPPER QUADRANT TUBULAR POST SIGNAL KIT

**Complete kit to build a working (un-motorised) home or distant signal up to 30ft tall. Some marking out, cutting and shaping of parts is required.**

Although upper quadrant arms had been in use since shortly after the Grouping, the LNER tubular post signal dates from the mid-1930s. It was used for new installations and renewals until the end of the LNER period, and by the Eastern and North Eastern Regions of British Rail(ways). The design does not appear to have been common in Scotland, probably because the pre-grouping signals used lattice posts, which would have remained in better condition than the timber posts used south of the border. Many examples are still in use today, and new ones may still be installed

where replacement by colour lights is inappropriate.

### Parts supplied:

- S012/1 arm etc fret
- S09/5 ladder fret
- SC025 lamp casting
- SC029 post cap casting
- 250mm x 1/8" brass tube (post)
- 100mm x 5/32" brass tube (butt)
- 30 x 2mm brass tube (arm bearing)
- 30 x 1.0mm brass rod (arm spindle)
- 30 x 0.9mm brass rod (balance weight axle)
- 30mm x 22swg nickel silver wire (crank axle)
- 250 and 3 off 50 x 0.45mm brass wire (operating wire, arm stop, stanchions)
- Red, yellow and blue-green glazing
- Baseplate

### ASSEMBLY INSTRUCTIONS

#### General:

The test kit was built using 50W and 25W (low temperature) soldering irons, 188°, 145° and 70° solders and liquid fluxes, minidrill and slitting disc, various files, pliers, drills etc, and tinsnips and small scissors for cutting out the frets. In these instructions left- and right-hand mean as viewed from the front of the signal. A selection of prototype photographs will help assembly, and these should be easy to find, as this type of signal was very common.

Burnish both sides of the frets before removing any parts. It will help to tin some of the smaller parts before removal. Parts 5a and 6a on the S012/1 fret are not required and may be discarded. Grip the etched parts in smooth pliers when filing off tags to avoid bending them.

#### The Signal Arm:

Use 188° solder for this section.

Open out the spindle hole in the spectacle plate (3) to no.61 (1.0mm). Using the half-etched lines as a guide, scribe painting lines on both sides of the appropriate signal arm – home (1) or distant (2):

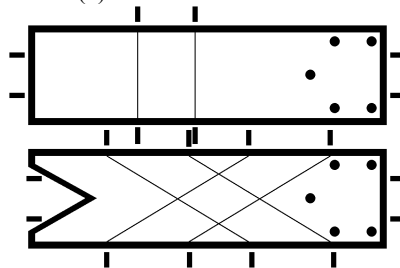

To do the rear side, use a scriber to punch guide pips through from the front marks.

Punch out the five bolt heads in the chosen arm, then solder it to the half-etched side of (3), ensuring the bolt heads project on the front face. Solder the arm assembly to the 30 x 1.0mm brass rod spindle. To keep things square, drill a 1.0mm hole in a wood block, insert the spindle then drop the arm on to it face down. When soldering, do not press the arm at the spectacle plate end, or it will tilt. Remove the excess front spindle and file it almost flush with the spectacle plate. Leave

the excess rear material for now as a painting handle. Joggle the operating wire arm back 1mm so the operating wire will clear the spectacle plate.

#### The Post:

Use 188° solder for this section, except where stated.

Tubular posts were made in two parts, the post and the butt. They usually came in one of a range of standard heights, chosen to give adequate sighting, as shown in the first column of the table. The height given is the height of the arm centre-line above rail level, so the post cutting length given in the second column includes an allowance of 16mm and 8mm at the top and bottom of the post respectively.

These figures include 2mm for the recess inside the post cap and 1mm to go into the baseplate. Non-standard cutting heights can thus be calculated from the table - don't forget to make allowance for any signal not mounted on the ground. Note that a platform starter is typically 16ft high, and that posts above 20ft were usually fitted with a lampman's platform. The position of the platform varied, with the handrail being mounted on the post below the lamp bracket (as in the heading photograph), or above the arm bearing. Generally, the former applied to signals in the LNER's Southern Area (BR Eastern Region) and the latter to the rest of the LNER (effectively BR North Eastern Region). For convenience, these variants will be referred to as ER and NER signals in these notes.

Height (ft/ins)	Post cutting length (mm)	Butt cutting length (mm)	Post to ladder distance (mm)
16.0	136.0	49.0	18.0
20.0	164.0	49.0	20.5
22.6	181.5	77.0	24.0/25.5
25.0	199.0	77.0	25.5/27.0
27.6	216.5	77.0	27.0/28.5
30.0	234.0	77.0	28.5/29.5
32.6	251.5	77.0	29.5/31.0
35.0	269.0	77.0	31.0/32.5

In the fourth column, the first figure applies to ER signals, and the second to NER signals. Heights above 30ft will require an extra S09/5 ladder to be purchased and joined, and you will not be able to have the post inside the full length of the butt.

Having chosen your post height, cut the 1/8" and 5/32" brass tubes to the lengths shown in the second and third columns of the table respectively. Ensure that the ends are square. If not mounting the signal on the baseplate, remember to add sufficient length (the same to both tubes) for your chosen fixing method.

Attach the 2mm bearing tube to the post at right angles 9mm below the post top – again, a hole drilled in a wooden block will help keep things square. Use the minidrill and slitting disc to trim the bearing so it projects 1.5mm beyond both the front and rear of the post (the post faces, not its centre line).

If modelling a post over 20ft tall, add the platform mounting block (4). Place the post through the centre hole, then solder the block square on and 42mm (ER) or 24.5mm (NER) below the arm bearing centre line. Use the slitting disc to cut back the front face of the block so the post just "breaks through".

Solder the post tube inside the butt tube, leaving 1mm of the post projecting at the bottom if using the baseplate. File the characteristic bevel to the butt top.

If using the baseplate, scribe a longitudinal centre line along it, then drill a 1/8" hole on the line around 25mm from one end. Solder the post/butt assembly to the baseplate, ensuring squareness in all three planes.

Temporarily fit the arm spindle into its bearing, and solder (145°) a 0.45mm wire stop in the crook of the bearing/post joint, as shown below. This will prevent the arm falling below the horizontal. You may need to file down the top of the spectacle plate or the underside of the wire to give a free motion.

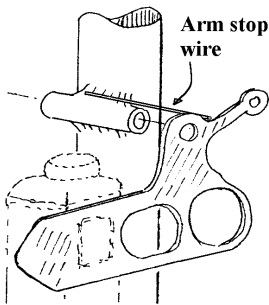

### The Balance Weight and Post Fittings:

Use 188° solder for the start of this section.

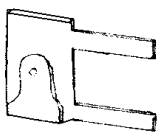

Sweat the two balance weight levers (5) together. Add weights (6) either side to increase the thickness as desired. Open out the

axle hole to no.65 (0.90mm), and the two operating wire holes to no.77 (0.45mm). Fold up the bracket (7), as shown, with the half-etched lines on the **inside** of the bends. Now switch to 145° solder.

Solder the bracket to the right-hand side of the butt, with the straps pointing to the rear. The bearing hole should be 35mm (5ft) above the baseplate/ground level, unless the signal is in a public area, when it should be raised up on the post, within reach of the platform. Wrap the straps around the butt, then solder them in place. Using the bracket bearing holes as a guide, drill no.65 (0.90mm) right through the butt. Insert the 0.9mm brass bearing wire, trapping the balance weight arm in the bracket such that the weight is to the rear of the signal. Oil the balance weight arm bearing, then solder the wire at the butt and bracket hole outer faces. Remove excess wire and tidy up the joints.

Consider from which direction the signal box operating wire would have approached the signal. Solder a crank (9) to the front of the bracket (8), using the nickel silver wire axle,

such that when the bracket is soldered to the front or right-hand side of the butt as appropriate, a horizontal pull on the lower lever will translate into a downwards pull on the other lever. Use one of the etched brass washers to space the crank off the bracket. There is no need to make the crank work, unless it is to form part of the eventual operating mechanism. Some signals had a pulley wheel (10) instead of the crank, but this does not appear to have been very common. [For a working crank/pulley, solder (188°) the axle into the bracket, add a brass washer, then the crank or pulley, a paper washer, then solder (145°) a second brass washer on top.] Finally, solder the bracket to the front or right-hand side of the butt, so the lowest crank hole is just above the baseplate/ground level, and the half-etched bolt-heads are facing outwards and are symmetrical about the butt.

Fold up lamp bracket (11), with the half-etched line on the inside. Solder (188°) triangle (12) into the half-etched lines inside the bend; one is longer than the other to match the triangle sides. Solder the bracket to the left-hand side of the post, so its top surface is 10.5mm below the arm bearing centre line, and the shortest side of the triangle is against the post.

Add the track circuit plate (13) if needed (not on distant signals). Centre it 91mm (13ft) above the baseplate/ground level, and use 188° solder, as ladder bracing struts are likely to be added later in the same area. Two pairs of bolt holes are half-etched into the plate. Either the vertical or horizontal pair was used to fix the plate to the post; if modelling an actual prototype, check from photographs which pair is redundant and fill with solder.

### The Platform and Ladder:

Use 145° solder for this section unless otherwise stated.

Use the minidrill and slitting disc to form a 10mm long channel in the baseplate, perpendicular to the centre line. The distance from the butt depends on the post height - see the last column of the height table. If not using the baseplate, solder pieces of scrap wire either side of the butt which are long enough to reach the ladder end. For non-standard post heights below 20ft, take the post cutting length in millimetres, subtract 5, divide by 12, add 7, and the result is the distance of the ladder foot from the rear of the post. For ER signals above 20ft, subtract 51, divide by 12 and add 13; and for NER signals above 20ft, subtract 33.5, divide by 12 and add 13.

### **Post height 20ft or less:**

Solder ladder mounting block (4) 4mm below the post top. Use the slitting disc to cut back the front face of the block so it is just in front of the post.

### **Ladder mounting block**

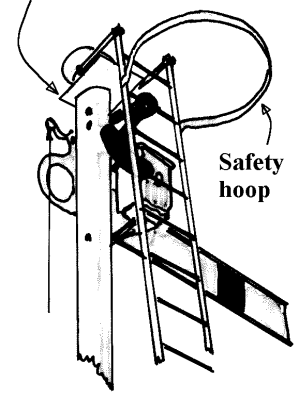

Remove the end rung from the ladder S09/5. Bend the side stiles over at around 105° just above the new top rung, with the half-etched side on the outside of the bend. Cut the ladder to length, so its bottom end fits in the baseplate channel or can be soldered to the fixing wires, and its top end fits around the mounting block. Solder the ladder top and bottom; the top bend should be positioned 7mm from the rear of the post.

Form the safety hoop from strip (14). Wrap it round a 15/32" or 12mm drill; the natural spring of the brass will open it to the correct 14mm diameter. Bend the end tags to the ladder width and solder them to the outside of the ladder stiles, 10.5mm below the arm bearing (level with the lamp bracket).

### **Post height above 20ft:**

Remove the platform (15) and handrail (16) from the fret. Cut off the last two treads. The handrail needs to be 24.5mm (ER) or 28mm (NER) above the platform, so add two overlength 0.45mm stanchions through the hole in the platform, with the half-etched side of the latter on top. An easy way to do this is to take a 1/4" balsa block, lay the platform face down on it, drill two no.77 holes through the block using the holes in the platform as a template, insert the stanchions through the holes and solder (188°) in place.

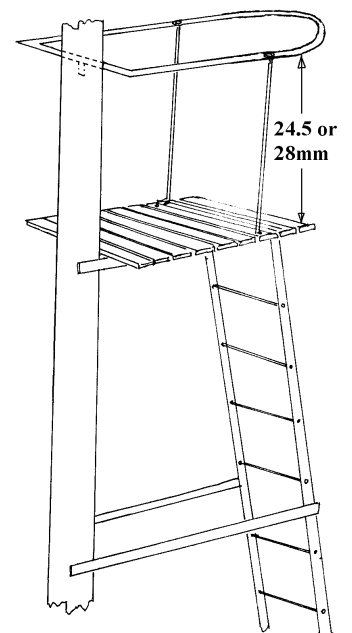

Use pliers to grip the handrail across the two stanchion holes, then gently bend the handrail (start by squashing in the corners) to make it semi-circular in plan. Fold down the tag so the half-etched line is on the **inside** of the bend. Place the handrail over the stanchions, and then solder it in place 24.5 or 28mm above the platform as indicated above. Remove any excess wire with side cutters. As these will not cut exactly flush, a "bolt-head" is naturally left at each cut.

Bend in the two tags on the platform so they grip the mounting block, then solder the handrail tag to the rear of the post and the platform tags to the mounting block sides. The nearest platform tread should not be soldered to the mounting block, otherwise the platform will not be level. Note that on an ER signal, the handrail/post joint is very near that between the lamp bracket and post, so you may need to clamp the latter to prevent it unsoldering.

Cut the side stiles from the top end of the ladder, thus leaving a rung as the topmost edge. Cut the ladder to length, so its bottom end fits in the baseplate channel or can be soldered to the fixing wires. Solder the ladder top and bottom, with the half-etched side to the rear.

#### **All post heights:**

Add pairs of ladder bracing struts (17). Solder them to the ladder and post, joggling them to account for the width difference. Check their height and number with photographs. The ladder end joints should be on the outside of the stiles, and never exactly level with a rung. Remove any excess tag or strut length and tidy up.

#### **The Lamp and Post Cap:**

Use 70° solder for this section.

Remove any casting sprue and mould lines from the lamp and post cap. Use a piercing or razor saw to remove the bracket from the lamp; make the cut along the narrower part of the casting immediately above the bracket. Solder the lamp to the bracket, so that in side view, the lamp body is in line with the post, and from the front, the lamp lens falls behind the left-hand arm spectacle. Finally, add the cap to the post top.

#### **Painting:**

Degrease the post and arm assemblies by washing in detergent water and leaving to dry. Spray overall with white car primer, mounting the arm in its bearing to avoid painting the spindle and inside of the bearing tube. Detail paint as follows (but check with photographs as there is a lot of prototype variation):

**Black (some parts pale grey in later BR days):** – butt to just above and including the balance weight assembly; ladder above the level of black on the butt and any bracing struts above this, but not the mounting block; safety hoop or platform; lamp, but not the lamp bracket; arm bearing; a band on the post 7mm deep above and below the track circuit

plate; arm spectacle plate including the V-shape on its reverse; arm rear band/chevron; front chevron on a distant arm.

**Red or Yellow:** front and edges of the arm except the home's white band or distant's black chevron. If the primer has filled your scribed guide lines, here is a full-size template for marking out again:

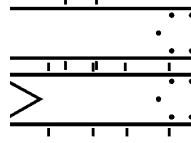

**Silver:** lamp lenses front and rear.

Glaze the spectacles; use red (home) or yellow (distant) in the left-hand aperture, and blue-green in the right-hand one. The easiest method is to cut a rectangle approximately to size so the whole of the aperture is covered, fix it in place using MSE's *GSA* adhesive or gloss varnish, and then trim the edges when set. Coat the front of the glazing with gloss varnish to give a better glass effect.

#### **Fixing the Arm to the Post:**

Use 145° solder for this section.

Ensure the spindle moves freely in its bearing – clean off any paint that might have crept in. Remove any excess spindle length with the slitting disc, but leave enough protruding through the bearing to solder the back-blinder on. Open out the hole in the back-blinder (18) to no.61 (1.0mm). Place an oiled paper washer over the spindle end, then solder on the back-blinder, with its reinforcing rib to the rear. Adjust its position so it just clears the lamp rear lens when the arm is horizontal, and push it sufficiently far on to the spindle to remove any fore and aft spindle motion. Wash off any surplus flux, then prime and paint black or light grey as detailed above.

#### **The Operating Wire:**

Make a small hook in the top of the 0.45mm brass wire. Measure the distance between the arm hole (arm horizontal) and the inner balance lever hole (lever around 30° below the horizontal). With the short end of the hook facing you, bend the bottom of the wire 90° to the right at the measured distance. Put the hook in the arm hole so the wire is to the rear, and then the bottom bend through the balance lever hole from the left-hand side, forming a hook to retain it. The wire can pass in front of or behind the track circuit plate - both are found on the prototype. Prime the wire and paint it black, or to avoid the risk of gumming up the works with paint, use a permanent marker pen instead.

The signal may now be installed on the layout and connected to your chosen means of operation.