

ANDREW HARTSHORNE

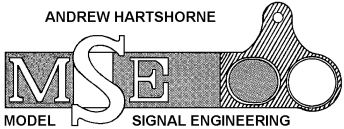

MODEL SIGNAL ENGINEERING
PO BOX 70 BARTON upon HUMBER DN18 5XY
01652 635885 www.modelsignals.com

SCALE	CODE	PRICE
7 mm	S025	£ 5.00

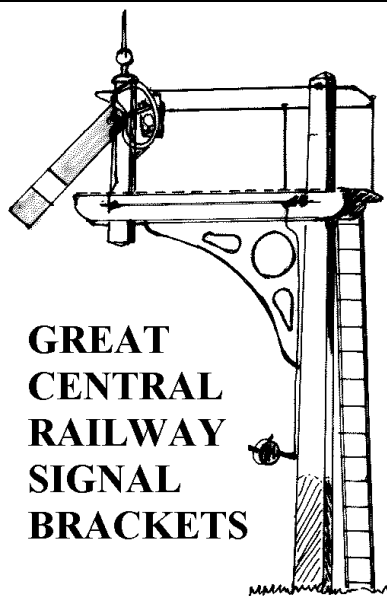

GREAT CENTRAL RAILWAY SIGNAL BRACKETS

Suitable for 1 to 3 doll brackets (equal tee or offset)

Note: this kit contains bracket and landing components only, for an offset doll using a 3'6" or 4'0" supporting bracket. Use two 4'0" brackets for a 3-doll cantilever or equal tee bracket. For a complete signal, you will need: a base post (S028); dolls (S033); signal arms (S03 GC lower quadrant or S012/1 LNER/BR upper quadrant); finials; lamps (SC023 lower quadrant or SC025 upper quadrant); and a ladder (S7/09, S09/3, S09/4 or S09/5).

Obtain good photographs before starting work. Remember that many changes took place during the lifetime of signal brackets, from their earliest installation by the Great Central Railway, when the signal would have been in the original lower quadrant condition, to later modification when Board of Trade changes were needed, then through the Grouping and Nationalisation, which would have seen the renewal of components with more up-to-date items, including upper quadrant fittings in the later days.

ASSEMBLY INSTRUCTIONS

Burnish both sides of the frets, then tin all parts before removing. Prepare a length of base post S028 by removing the top bearings and if reducing its height, ensuring that you have a minimum of 13'6" clearance remaining between rail head and the underside of the proposed bracket, at any point where it will foul a running line. Cut to length sufficient S033 dolls, remembering that the bottom of the doll should protrude beyond the bottom of the trimmers. Complete the dolls by adding the appropriate bearings, lamps and finials. The arms should be added after painting.

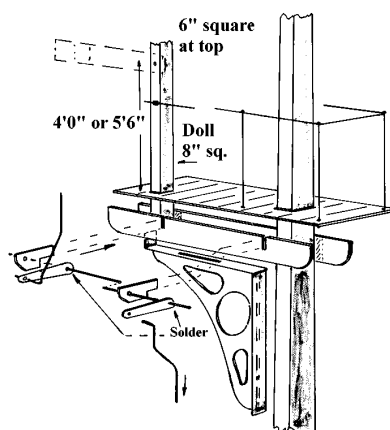

Remove the trimmers from the fret and split them into linked pairs. Fold each pair back-to-back (half-etched lines on the inside) and sweat together. Remove the resulting "tags".

Make up the large or small bracket as shown, such that the larger tab and slot is at the top. The upward folding tab acts as a spacer for the trimmers. Solder the bracket to the side of the post, ensuring that the top surface is horizontal (you will need to compensate for the post taper). Add the trimmers, with the slotted one to the front as shown. Open out the holes in the rocking shaft support brackets to suit a 0.70mm axle, then solder them to the front trimmer. Open out the holes at wider end of the rocking shaft levers to suit the same 0.70mm wire, and the other holes for 0.45mm operating wires. Thread the levers onto the rocking shaft as shown, and solder the levers in place. Use the minimum of flux to ensure that no solder flows into the bracket holes.

Drop the landing down onto the main post and solder it to the trimmers, such that the longer overhang is to the rear. You may need to open out

the square hole in the landing to do this. Solder the doll in place.

Establish the handrail stanchion positions from your prototype photographs, as they do vary a great deal. Note that the front handrail was often fixed to the posts. Drill the landing perimeter at the chosen intervals with a no.76 drill, and insert scale 3' to 4' lengths of 0.45mm brass wire into each hole, from below, with a short "L" turned on the bottom of each one. A quick solder joint on each one will fix them in place, then they can be aligned by eye, and a handrail of brass or soft iron wire fixed around, one stanchion at a time. Leave a hoop at the rear where the ladder will be attached. Finally, trim off all excess wire.

Solder the chosen ladder to the landing rear, adding two bracing stays from thin brass strip midway up the base post. Taller dolls may also require their own ladder, as shown overleaf. Also fix the appropriate balance levers to the base of the post.

PAINTING

Clean the signal by immersing in warm detergent water, rinse under a running tap, then allow to dry overnight. Spray overall with white primer. In general terms, wood can be left white, with ironwork and the bottom 4' of the base post bauxite in GC days, and black in LNER/BR days. However, there are many exceptions, so beware!

The arms, back blinders and operating wires may now be added, and the signal installed on the layout. Many bracket signals had bracing wires and posts, so don't forget to add these.

© Model Signal Engineering 2006

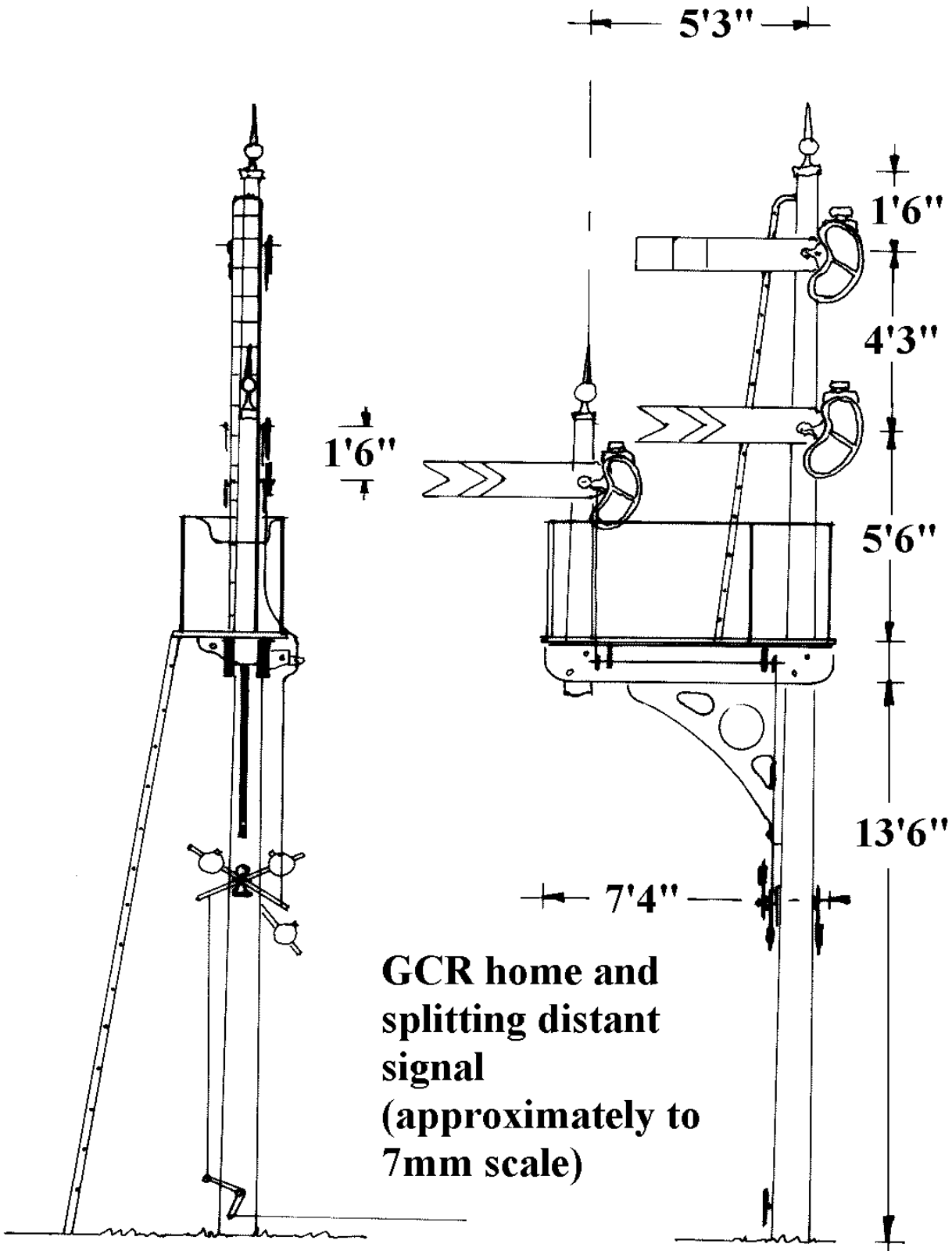

**GCR home and
 splitting distant
 signal
 (approximately to
 7mm scale)**