

## MIDLAND RAILWAY LOWER QUADRANT

## WOODEN POST SIGNAL KIT

**Complete kit to build a working (un-motorised) home or distant signal in any height up to 27ft. Some marking out, cutting and shaping of parts is required.**

This kit represents the type of signal used by the Midland Railway from the 1900s onwards, through the LMS period and into BR days. Lower quadrant arms were still much in evidence in the late 1950s and it was only in 1960s that the majority of Midland posts received upper quadrant arms, while still retaining most of their earlier fittings. At least one lower quadrant arm can still be found on Network Rail today, along with several on the various preserved lines.

The kit may be built with either the earlier wooden arm, or the later corrugated steel arm. A short subsidiary arm is also included.

### Parts supplied:

- S005/1 arm etc fret
- S006 wooden post casting
- S009/4 ladder fret
- SC0012 finial casting
- SC0023 lamp casting
- SC0041 balance lever & bracket casting
- SC0042/1 balance weight casting
- Baseplate
- 30 x 0.8mm brass rod (arm axle)
- 150 x 0.31mm brass wire (2 pieces, operating rod & guide, handrails, arm corrugations)
- 30 x 0.45mm brass wire (support bearing)
- 30mm x 22swg nickel silver wire (balance lever axle)
- 40 x 1.0mm brass rod (four post pegs)
- Red, yellow and blue-green glazing

### ASSEMBLY INSTRUCTIONS

The test kit was built using 50W and 25W (low temperature) soldering irons, 188°, 145° and 70° solders and liquid fluxes, minidrill and slitting disc, various files, pliers, drills etc, and tinsnips and small scissors for cutting out the frets. A selection of prototype photographs will help assembly; choice examples can be found in the "Midland Record" series.

Burnish both sides of the frets before removing any parts, and tin the smaller parts before removal. Grip the etched parts in smooth pliers when filing off tags to avoid bending them. Unless stated otherwise, all half-etched fold lines go on the inside of the component. Left- and right-hand mean as viewed from the front of the signal.

**Note:** Model Midland signal construction is unusual as the arm rotates on an axle fixed to the post, rather than the normal arrangement of the axle being fixed to the arm, and rotating in a bearing tube fixed to the post. To align the various arm components, use an oiled wire axle or the point of a needle (or anything else that won't take solder).

### The Signal Arms:

Use 145° solder for this section except where stated otherwise.

Before removing any parts from the fret, and if required for your chosen signal, score the home stripe onto the arm using the marks on the fret as a guide. To do the rear stripe, use a scriber to punch guide pips through from the front marks. If modelling a distant signal, cut the characteristic V-shaped notch in the end of arm (1) or (7).

### Wooden arm:

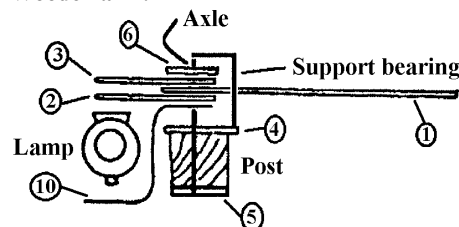

Tin both sides of the hole end of arm (1), and solder the arm on top of rear spectacle plate (2). Tin both sides of the hole end of front spectacle plate (3) and solder this on top of (1). Do not allow the gap between (2) and (3) to close up. Pop a vertical row of three rivets down the right-hand edge of plate (6), then solder it on top of (3).

### Steel arm:

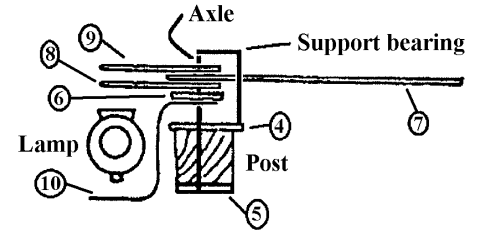

Solder (188°) two lengths of 0.31mm brass wire onto the rear of the arm to represent the corrugations, using the holes in the fret as a guide. Tin both sides of the hole end of arm (7). Solder the arm on top of rear spectacle plate (8), removing excess corrugation wire as required. Checking with photos for position, pop two rivets onto the front of front spectacle plate (9) then solder it on top of (7). Do not allow the gap between (8) and (9) to close up. Solder plate (6) onto the back of (8); this is not prototypical, but it will strengthen the operating rod hole on a working signal.

### Subsidiary arm:

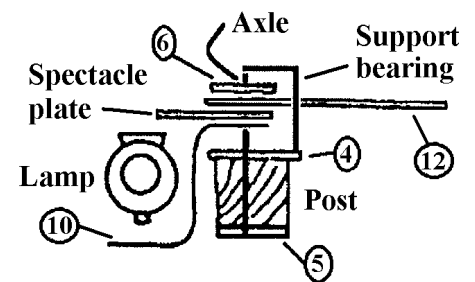

Tin both sides of the hole end of arm (12), and solder it on top of the small spectacle plate (unnumbered). Pop a vertical row of three rivets down the right-hand edge of plate (6), then solder it on top of (12). The operating rod hole will need re-drilling.

**For all arms:** Place back-blinder (10) flat on the bench, with the blinder to the left and its smaller half to the top. Bend the blinder to the right, around 2mm from the hole, then solder it to the back of the arm, aligning the hole with the arm pivot hole. Do not put the second bend in yet, so the arm can easily be fitted to and removed from the post. Open out the axle hole to 0.80mm (no.68), and the operating wire hole to 0.45mm (no.77).

### The Post and its Fittings:

**Warning:** being cast in whitemetal, the post is easily melted or distorted. Handle it carefully, and ensure you have picked up the low-temperature (70°) iron before making any joints!

The post as supplied will build into a signal 27ft high. If you require a shorter post, remove the excess from the top end of the post - MR signals always seemed to have a "chunky" appearance, and the cast motion plates are not required. Fill the notch around the post about

1cm from the base, then remove any flash and mould lines, file off the motion plates and square the post ends. Always try to file along the length of the post rather than across it, so any file marks look like timber grain. Straighten the post using gentle finger pressure if it has become distorted.

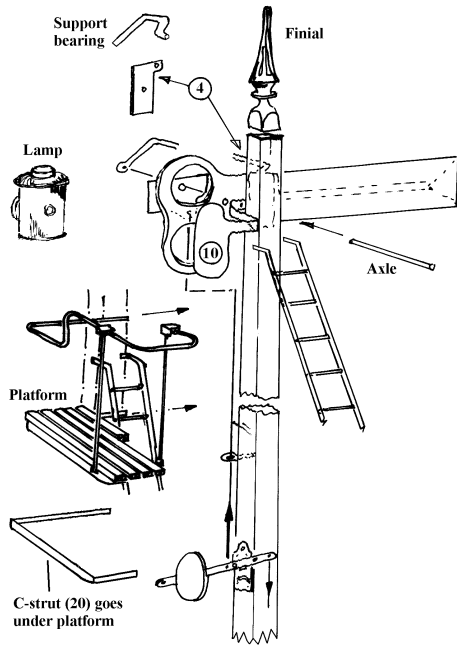

Mark the arm axle hole on the front face (a face that had a motion plate on it) centreline, 4mm from the post top. Drill 0.8mm (no.68), and solder (70°) in the 0.8mm brass rod axle, leaving plenty spare on both sides. Place plate (5) over the rear axle and solder (70°) it to the post, with the V pointing downwards. Cut off the excess rear axle and file it flush with (5). Open out the small hole in plate (4) to 0.45mm. Tin (145°) both sides, place it over the front axle, and solder (70°) it to the post, with the small hole to the top left.

Tin (145°) both sides of lamp bracket (11), bend into an L shape, and reinforce the angle with solder. Solder the bracket to the right-hand side of the post, with the bracket top level with the top of the front motion plate. (You may wish to use a 1.0mm brass rod peg to reinforce this joint, in which case the peg hole should be 1mm below the plate.)

Separate the balance lever and bracket from the casting sprue. File down the sides of the bracket so it matches the width of the post. Open out the small holes in the lever to 0.45mm (no.77), and the larger hole and the holes in the bracket to 0.60mm (no.73). Drill 0.60mm right through the side of the post, on the vertical centreline and 18mm high (this latter dimension does vary, so check with photographs).

Insert the straightened nickel silver bearing wire, trapping the balance weight arm in the bracket such that the longer portion is to the left of the bracket. Oil the balance weight arm bearing, then solder (188°) the wire at the bracket hole front and rear faces. Push the wire at the rear of the bracket through the hole drilled in the post, and solder (70°) the whole assembly to the right hand side of the post. Drill a 0.6mm hole in the centre of a second

plate (5), place on the left-hand side axle, and solder (70°) it to the post, with the V pointing downwards. Remove excess wire and tidy up the joints. Solder (70°) the weight to the arm, around 1mm from the end.

### The Platform and Ladder:

Start with 188° solder for this section. Take care with the platform - it is easily twisted or broken.

Tin strut (20) on all edges and faces, and bend it to a square C shape, with the centre portion forming the vertical of the C (i.e. ignore the two outer half-etched fold lines, and make just two bends). Solder it to the platform bottom, such that the vertical of the C is under the middle of an outer plank, and when the platform is viewed as shown, the ends of the C are to the right, and the longer horizontal is at the top. With the platform in this position, cut the plank at the open end of the C halfway along its length, and remove the bottom half (i.e. that over the shorter horizontal), together with the underlying portion of the strut. The cut-away corner is now designated the rear left-hand one, relative to the post.

Cut notches on the left and right-hand sides of the platform at both rear corners to take wire stanchions. Some signals also had a stanchion on the front right-hand corner. Solder on (145°) stanchions made from 0.31mm brass wire, at least 15mm long. Bend up a 0.31mm brass wire guardrail, to the shape shown above, but do not make the bend at the front of the platform just yet. The downward step is halfway along the platform, and 2mm deep. Solder (145°) the guardrail to the stanchions, 1mm above the platform.

Offer up the completed platform to the rear of the post. Bend the front of the guardrail so it sits against the rear of the post when the strut is also placed at the post rear. Solder (70°) the strut to the rear of the signal post, such that the platform treads are around 3/4mm from the post side, and the lower level of the guardrail is just below the lamp bracket. Solder (70°) the guardrail to the rear of the post. You will need to clamp the lamp bracket to the post when making these two joints. Trim off any excess strut, stanchion and guardrail. Some signals had diagonal bracing from the post to the two right-hand corners of the platform - check with photographs.

If you intend to use the large rectangular baseplate to mount the signal on the layout, first scribe a longitudinal centre line along it. Orient the post with the balance weight on the right, then solder the post around 15mm from one end of the baseplate, ensuring squareness in all three planes. Drill the post and baseplate and use a 1.0mm brass rod peg to strengthen the joint.

Use the minidrill and slitting disc to form a 5mm long channel in the baseplate, perpendicular to the centre line and 17mm from the post rear face. (If the post has been cut to a shorter height, the channel should be positioned to give a ladder slope around 1 in 8.) If not using the baseplate, solder pieces of

scrap wire either side of the post, which are long enough to reach the ladder end.

Remove the end rung from the ladder S009/4, then bend the side stiles over at around 105° just above the new top rung, with the half-etched side on the outside of the bend. Cut the ladder to length, so its bottom end fits in the baseplate channel or can be soldered to the fixing wires, and its top end fits around the post just below the guardrail joint. Jiggle the top of the ladder in to suit the post width, then solder the ladder top (70°) and bottom (145°); the top bend should be positioned 2mm from the rear of the post. The ladder should just touch the side of the platform, as shown.

Use spare ladder stiles to make bracing struts. Solder them to the ladder (145°) and post (70°), joggling them to account for the width difference. Check their height and number with photographs. The ladder end joints should be on the outside of the stiles, and never exactly level with a rung.

### The Lamp and Finial:

Use glue for this section, as soldered joints would be too close to previously assembled components.

Remove any casting sprue and mould lines from the lamp and finial. Glue the lamp to its bracket so that in side view, the lamp body is in line with the post, and from the front, the lamp lens falls behind the arm's top spectacle. Glue the finial to the post top. Its appearance can be improved by cutting a small square of waste fret or plasticard slightly larger all round than the finial base, and sandwiching it in the finial/post joint. Use 1.0mm brass rod pegs to reinforce the joints as necessary.

### Painting and Glazing:

Degrease the post and arm assemblies by washing in detergent water and leaving to dry. Put a drop of oil on the balance lever axle, then spray overall with red oxide (MR days) or white car primer, and spray the arm white.

Detail paint as follows (but check with photographs as there is a lot of prototype variation):

**Post etc:** For a pre-1923 signal, paint all exposed parts of the post lemon chrome (Railmatch 290 ARC Mustard Yellow is a good match), with all ironwork (including the finial) and the post below the balance lever bracket left as red oxide. Post-1923, the post should be left white, with all ironwork (except the support bearing) and the bottom of the post in black. Some signals had the bottom of the ladder painted white. Don't forget a dash of silver on the lamp lenses.

**Arms:** Pre-1911, all arms were red on the front face and white on the rear, with a white spot on the front, and a black spot on the rear. Some distant arms had a centred black horizontal line the full length of the reverse face instead of the spot. Between 1911 and 1925, all arms had a 10" wide white vertical stripe on the front face 11" from the end, with a corresponding black stripe on the rear. After

about 1925, this arrangement continued for home arms, but the front face of distant arms was painted yellow, with a black chevron both front and rear.

**Spectacle Plates:** These were painted black or red oxide prior to 1923, after which they were painted white (although some photos show them to be black). Home signals should be glazed with red in the top aperture and blue-green in the lower one. Distant signals should have blue-green glazing in the lower aperture, with the top aperture having clear glazing (if the arm is red), or amber if the arm is yellow. Use gloss varnish to stick the glazing material between the two halves of the spectacle plate.

#### **Fixing the Arm to the Post:**

Clean off any paint from the axle and the axle hole. Also clean out the 0.45mm hole in plate (4). Place the arm on the axle - you may need carefully to shorten the axle or bend the back-blinder to do this. Remove any excess axle length with the slitting disc, leaving around 0.5mm protruding above the arm face. Bend up the support bearing from 0.45mm brass wire as shown above; the U bend should be a loose fit over the arm.

Place the short end into the hole in plate (4), and solder (145°) the other end to the end of the axle at a frontal angle of approximately 45° to the left as shown above. Secure the plate end with glue. Carefully remove any excess wire from the axle end, then bend the bearing so it acts as a horizontal arm stop. Paint the support bearing with red oxide or white primer as detailed above.

Bend the back-blinder so its top edge is below the lamp's rear lens when the signal is on, but completely obscures it when the arm is lowered. You should find that the back-blinder arm acts as a stop to prevent the arm falling too far below the horizontal - a fall of 45-60° is acceptable. If outside these limits, adjust the back-blinder arm accordingly.

#### **The Operating Rod:**

Make a small hook in the top of the 0.31mm brass wire. Measure the distance between the arm hole in plate (6) (arm horizontal) and the front balance lever hole (lever around 30° below the horizontal). With the short end of the hook facing away towards you, bend the bottom of the wire 90° to the right at the measured distance, then trim the bent portion to 2mm in length. Put the hook in the arm hole so the wire is to the rear, then pass the bottom bend through the balance lever hole from the left, forming a hook to retain it. Bend up one or more narrow U-shaped rod guides from 0.31mm brass wire, and glue them in to pairs of holes drilled in the post's front and right-hand faces, with the operating rod in the bend. These will prevent the rod from flexing excessively when the signal is operated. Small loco handrail knobs may be used instead, but remember to thread them onto the operating rod before making the lower bend. Paint the rod and guides with red oxide primer or black as detailed above.

The signal may now be installed on the layout and connected to your chosen means of operation.

© Wizard Models 2007