



L&YR and SE&CR SIGNAL BRACKETS



Suitable for 1 to 3 doll brackets
(equal tee or offset)

Note: this pack contains bracket and landing components only, for one 5'4" and a pair of 2'8" brackets. Use two 5'4" brackets for a 3-doll cantilever or equal tee bracket. For a complete signal, you will need:

Part	L&YR	SE&CR
Main post	S0017 or S0028	
Dolls	S006	
Finials	SC0013 or SC0017	SC0016 or SC002
LQ arms	S0013	S0011
UQ arms	S0012/1	S0012/1
LQ lamps	SC0023	SC001
UQ lamps	SC0011	SC006
Ladder	S009, S009/3, S009/4	

Typical formations are shown overleaf.

Obtain good photographs before starting work. Remember that many changes took place during the lifetime of signal brackets, from their earliest installation by the L&YR/SE&CR, when the signal would have been in the original lower quadrant condition, to later modification when Board of Trade changes were needed, then through the Grouping and Nationalisation, which would have seen

the renewal of components with more up-to-date items, including upper quadrant fittings in the later days.

ASSEMBLY INSTRUCTIONS

Burnish both sides of the frets, then tin all parts before removing. Prepare a length of base post by removing the top bearings and if reducing its height, ensuring that you have a minimum of 13'6" clearance remaining between rail head and the underside of the proposed bracket, at any point where it will foul a running line. Cut to length sufficient S006 dolls, remembering that the bottom of the doll should be level with the bottom of the trimmers. Standard heights are shown in the table overleaf. Complete the dolls by adding the appropriate bearings, lamps and finials. The arms should be added after painting.

Remove the appropriate trimmers from the fret, as shown below. Punch out the half-etched bolt heads, then fold each pair back-to-back (half-etched lines on the inside) and sweat together. Remove the resulting "tags". The trimmers are the correct shape for the L&YR, but for the SE&CR, the curved ends need reshaping:



Large bracket:

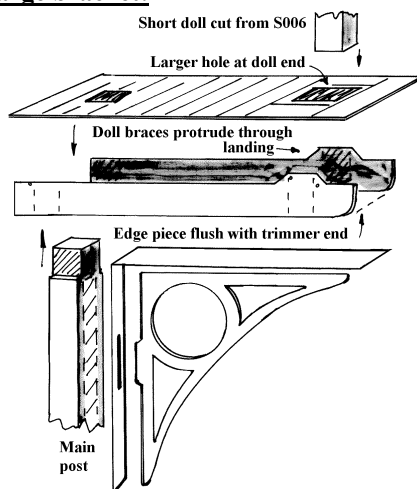

Solder the bracket into the edge piece, then solder this assembly to the side of the post. Ensure that the top surface is horizontal (you will need to compensate for the post taper). Add the trimmers, rebating the main post as shown.

Small bracket:

Solder the brackets to the main post, with the larger triangles at the top, followed by the trimmers.

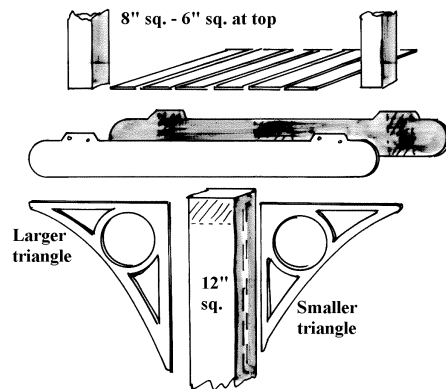

All signals:

Drop the landing down onto the trimmers, and solder it in place. If using a through main post, rather than a separate doll, you may need to open out the smaller square hole in the large landing to do this. Solder the doll(s) in place.

Establish the handrail stanchion positions from your prototype photographs, as they do vary a great deal. Drill the landing perimeter at the chosen intervals with a no.78 drill, and insert scale 3' to 4' lengths of 0.31mm brass wire into each hole, from below, with a short "L" turned on the bottom of each one. A quick solder joint on each one will fix them in place, then they can be aligned by eye, and a handrail of brass or soft iron wire fixed around, one stanchion at a time. Leave a hoop at the rear where the ladder will be attached. Finally, trim off all excess wire.

Solder the chosen ladder to the landing rear, adding two bracing stays from thin brass strip midway up the base post. Taller dolls may also require their own ladder, as shown. Also fix the appropriate balance levers to the base of the post.

PAINTING

Clean the signal by immersing in warm detergent water, rinse under a running tap, then allow to dry overnight. Spray overall with white primer. In general terms, wood can be left white, with ironwork and the bottom 4' of the base post bauxite in pre-Grouping days, and black after 1923. However, there are many exceptions, so beware!

The arms, back blinders and operating wires may now be added, and the signal installed on the layout. Many bracket signals had bracing wires and posts, so don't forget to add these.

© Wizard Models 2008

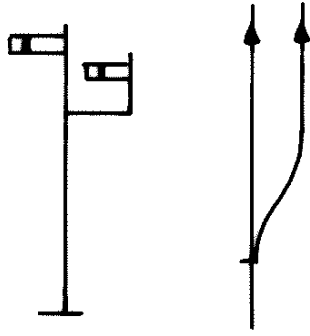

Offset junction signal

One large bracket. Lower arm 1'8" below the taller one.

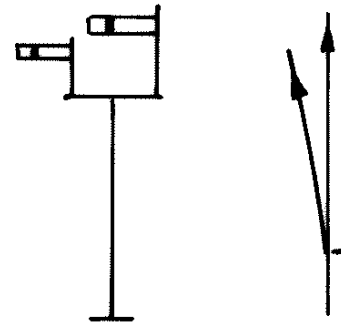

Equal tee 2-doll junction signal

Two small brackets. Lower arm centreline typically 7'0" above the landing, upper arm 8'8".

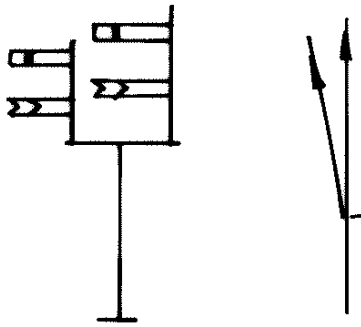

Equal tee 2-doll junction signal, with distant arms

Two small brackets. Home arm heights as before, distant arms 5'0" below.

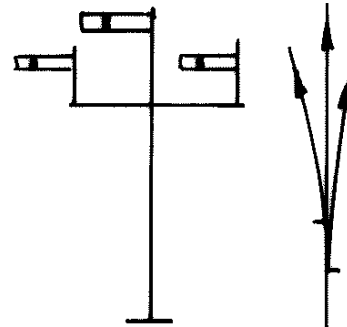

Equal tee 3-doll junction signal

Two large brackets. Arm heights as before.