

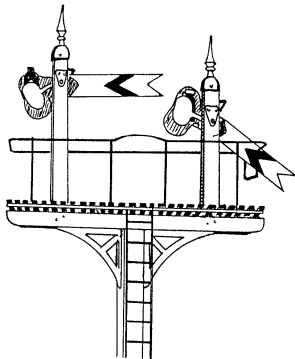

LNWR & MR SIGNAL BRACKETS

Etched components for one
equal tee bracket for each
company

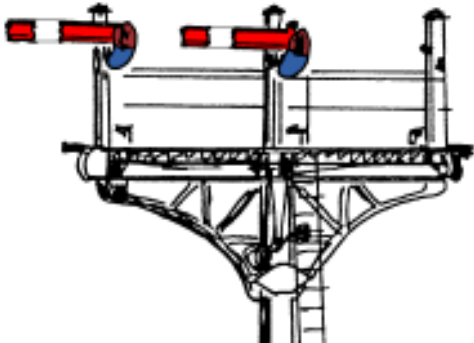

Note: this kit contains bracket and landing components only. For a complete signal, you will need: a base post and dolls (cut from SN17); signal arms (SN4/SN5 LNWR/MR lower quadrant or SN12/2 LMS/BR upper quadrant); finials (scratch built); lamps (SCN6); and a ladder (SN9 series).

Obtain good photographs before starting work. Choice examples may be found in the *Midland Record* and *LMS Journal* series. Remember that many changes took place during the lifetime of signal brackets, from their earliest installation when the signal would have been in its original lower quadrant condition, to later modification when Board of Trade changes were needed, then through the Grouping and Nationalisation, which would have seen the renewal of components with more up-to-date items, including upper quadrant fittings in later days. The LNWR components were also used for completely new upper quadrant signals in the early days of the LMS, sometimes with lattice base posts.

ASSEMBLY INSTRUCTIONS

Burnish both sides of the frets, then tin all parts before removing.

Prepare a length of base post SN17 by removing the top bearing and if reducing height, ensuring that you have a minimum of 13'6" clearance remaining between rail head and the underside of the proposed cantilever bracket, at any point where it will foul a running line. Cut to length sufficient SN17 dolls, remembering that the bottom of the doll should be level with the bottom of the trimmers. Complete the dolls by adding arms and lamps and finials.

Prepare a pair of trimmers from brass strip. Shape the ends as shown in the drawings opposite: square top corner, round bottom corner for the MR; rounded top and bottom for the LNWR). Solder the trimmers either side of the base post top. It is a good idea to

line and pin everything up on a balsa block so the job remains square in all directions.

LNWR

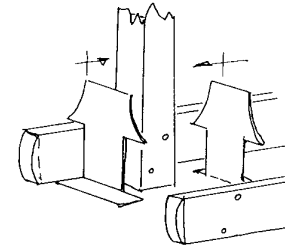

MR

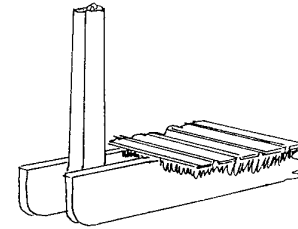

Solder the bracket flanges to the brackets, and the resulting assemblies to the post and trimmers. Finally, add the landing (scratch built for the LNWR); the front should be flush with the trimmer, with the entire overhang thus being at the rear.

Carefully make holes in the landing to accommodate the dolls. For a junction signal, these should be at least 6'6" apart (7' for the LNWR); dolls applying to parallel roads should be at least 10' apart. Solder in the dolls, using scrap etch to pack the gap between the dolls and the brackets/trimmers.

All working motion should now be undertaken to a satisfactory stage, before the addition of handrails, so as not to impede access. Small cranks tend to lose their efficiency due to poor bearings, so it is wise to provide small tubular bearings soldered unobtrusively into the bracket frame, and then to put the cranks onto short lengths of nickel silver wire as axles, with a washer soldered on the rear end to give a good movement. The wire linkages will perform that much better. Check the balance weight positions with photographs.

Establish the handrail stanchion positions from your prototype photographs, as they do vary a great deal. Drill the landing perimeter at the chosen intervals with a no.75 drill, and insert scale 3' to 4' lengths of wire (no more than 0.33mm diameter) into each hole, from below, with a short "L" turned on the bottom of each one. A quick solder joint on each one will fix them in place, then they can be aligned by eye, and a handrail of soft iron wire fixed around, one stanchion at a time. Leave a hoop or gap at the rear where the ladder will be attached. Finally, trim off all excess wire.

Solder the chosen ladder to the landing rear, adding two bracing stays from thin brass strip midway up the base post.

Nearly all bracket signals had bracing wires and posts, so don't forget to add these once the signal is installed on the layout.

PAINTING

Clean the signal by immersing in warm detergent water, rinse under a running tap, then allow to dry overnight. Spray overall with primer. In general terms, in MR days wood was painted lemon chrome, and ironwork bauxite. On the LNWR, wood was painted white, and ironwork and the bottom 4' of the base post brown or red oxide. The bracket castings themselves were painted a stone colour. Under the LMS and BR, wood was white (with the bottom 4' of the base post black) and all ironwork black. However, there are many exceptions, so beware!

