



Two doll square post cantilever bracket

Universally adaptable for tee brackets, 4 doll and gallows signals. Includes backing arm and goods line ring.

This is not a complete kit. For a complete signal you will need a base post and doll(s) (SN17), arms (SN14 series), ladder (SN9 series), lamps (SCN6) and finials.

This style of bracket was installed from the late Victorian period until it was superseded in the 1930s by the tubular steel design. The above drawing shows the standard formation for a diverging route signal.

ASSEMBLY NOTES

The parts are designed to give a 2 doll bracket on a 16-25' tall base post, which may or may not also form the taller doll, as shown in the sample formations below. The girders are always used in matched pairs. To produce a 4 doll bracket, the landing treads should be adjusted to provide a minimum of 6'6" (13mm) between adjacent dolls.

A minimum clearance of 13'6" (27mm) is needed between the rail head and the lower part of the bracket where it would foul the loading gauge. The root of the arch should be no lower than 10'6" (21mm) above the rail head.

The landing should overhang the brackets at the rear, where the ladder will be fixed. The etched handrail stanchion holes in the platform should be opened out to suit no more than 0.33mm diameter wire. The stanchions are easily made with a short L on one end, inserted through the hole from underneath, and soldered into place. The handrail should be bent up from the same wire and added 3' (6mm) above the platform, with the excess stanchion trimmed off afterwards.

When installing the bracket, remember to allow a minimum 5' (10mm) between the post face and the nearest rail.

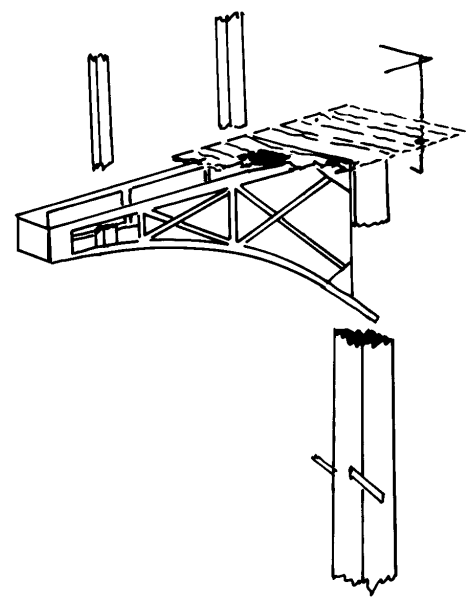
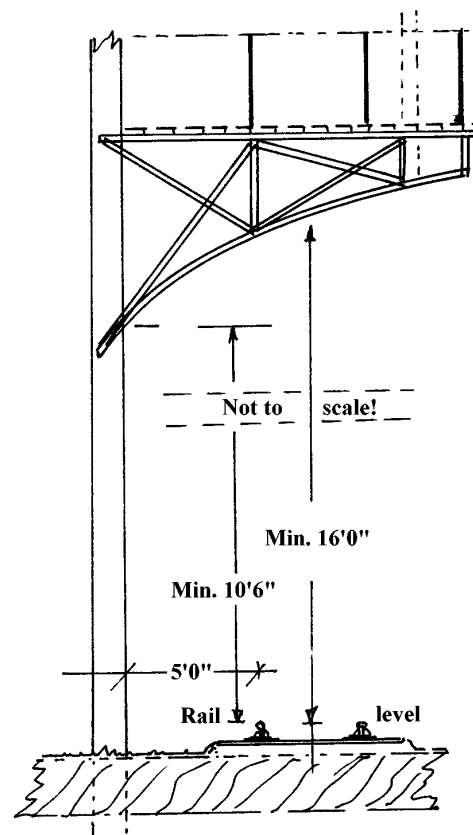

SAMPLE FORMATIONS MADE FROM ONE OR TWO SETS OF BRACKETS

