



**TUBULAR
POST
SIGNALS**
8 arms, 2-doll
junction bracket
& route indicator
Introduced 1928 and still in use

Identification and quantity of components on fret:

1. 4' distant arm (1)
2. 4' home arms (2)
3. 4' lipped edge home arms (2)
4. 3' home/siding arm (1)
5. 3' lipped edge home/siding arm (1)
6. Backing signal (up to 1947) (1)
7. 2'4" disc for bracket use (1)
8. Goods loop symbol (1)
9. Balance weights (7)
10. Spectacles (8)
11. Rule 55 diamond (1)
12. Backlight blinders (6)
13. Route indicator for low-speed diverging lines (1)
14. 2-doll junction bracket for tubular base post (1)
15. 16" discs for bracket use (2)

These arms appeared on many old square wooden posts during late GWR days and well into the BR(W) period when worn out wooden arms were renewed.

The parts are designed for soldered assembly. Use a 25-40W pencil bit iron with 188° and 145° solders and a liquid flux. Pinning parts to a balsa block helps keep

things square. Burnish both sides of the fret before removing any parts. It is easier to tin some parts before removal. Half-etched lines go on the inside of folds.

Straight post signal:

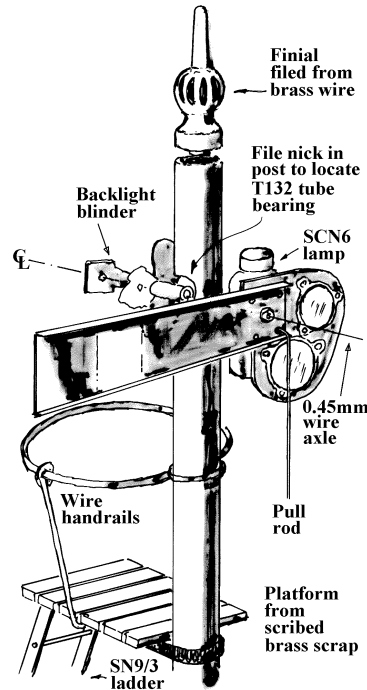

Select the appropriate signal arm, and a spectacle frame. Lay them on the block with a 0.45mm brass wire axle driven through the holes into the wood and solder together. Clear the pull rod hole, using a 5-sided broach for preference. If more than one signal is being made, do a batch, then spray them all over with white matt car undercoat. When dry, the final colours can be applied and the spectacles glazed with MSE LENS material. Set aside until the posts are complete.

Tubular posts were made in two parts, the post and the butt. They usually came in one of a range of standard heights, chosen to give adequate sighting, as shown in row A of the table below. The height given is the height of the arm centre-line above rail level, so the post cutting length in row B (use 1.0mm diameter brass rod) includes an allowance of 2mm at the top and bottom of the post respectively. Non-standard cutting heights can thus be calculated from the table - allow for any signal not mounted on the ground and for "planting" the signal into the baseboard or baseplate. Note that a platform starter is typically 16ft high, and that posts above 18ft were fitted with a lampman's platform.

A (ft)	16	17	18	19	20	21	22
B (mm)	36	38	40	42	44	46	48
A (ft)	23	24	25	26			
B (mm)	50	52	54	56			

The butt on all GW tubular post signals was 12ft tall above the rail, regardless of post height. A 3/64" diameter brass tube should therefore be cut to a length of 26mm. Solder the post rod inside the butt tube, then file the characteristic bevel to the butt top.

The post needs to have a bearing on the left-hand side, as shown, made from MSE T132 tube. File a nick in the side of the post to locate it prior to soldering it about 3mm from the top of the post.

Establish the correct lamp position by placing the arm axle into the bearing and with the arm at horizontal adjust the lamp so its lens is behind the upper spectacle. Solder it in place, using scrap etch if any packing is needed.

Balance weights were normally on the left-hand side of the post about 4' (8mm) from the ground. If this posed a danger to staff or public, then they were mounted 4'6" (9mm) below the arm at the front of the post. Fold scrap etch to make a bearing, with a 26swg nickel silver axle. The arm pull rod is attached to the hole nearest the weight, and the operating wire to the hole furthest from and in line with the weight.

Attach the ladder to the post via a small platform around 5mm square as shown. A circular handrail is attached to the post 6mm above it, with two uprights from the treads to the ring.

To complete the signal, add a finial from 1.0mm brass rod. After painting, place the axle through the bearing, and solder on the back blinder, using a paper washer to avoid straying solder. Connect the operating wire to your chosen means of operation.

Two-doll junction (not parallel roads) bracket:

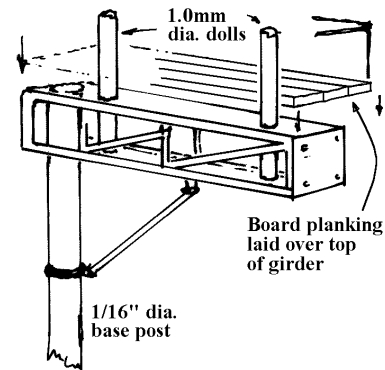

Fold up the bracket as shown and fix the root end to a length of 1/16" brass tube. The base post projects through the platform and is capped. The dolls are 1.0mm brass rod as before. The base post and nearest doll positions were reversed in BR(WR) days, as shown in the packet front drawing. The balance weights are at the base of the dolls, at the front. Use the third small hole on

the lever as an integral crank. Add stanchions and handrails from thin wire.

Route indicator:

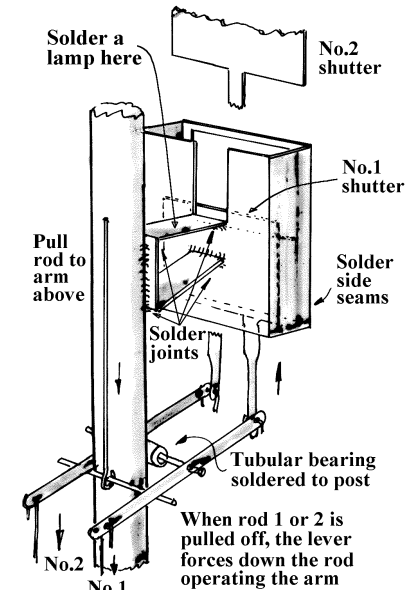

Make up the route indicator as shown above. It gives a compact method of signalling multiple low-speed routes from one stop signal. When the route is selected, the appropriate shutter rises from the casing, releasing the stop arm, which is then lowered.

Painting:

Generally, spectacles and ironwork are black, with posts and dolls white under the GWR and silver grey under BR(W). Stop arms are red with a white stripe 8" wide, starting 13" in from the outer end. Distant are yellow with a black chevron 5" wide (9" on the edges), 12" in from the outer end. The arm backs are white, with a black stripe or chevron repeating the symbol on the front. Discs are all white with a horizontal red stripe on the front. The backing arm is all red. For both arms and discs, the top lens is glazed red (yellow for distant), and the bottom one green. Shutters are black with white lettering when exposed to view.

© Wizard Models 2010